

Alabama Aquaculture
Best Management Practice (BMP)

**Managing Bait Minnow,
Sportfish and Grass
Carp Fingerling, and
Ornamental Fish
Culture Systems**

BMP No. 18



Definition

Several farms in Alabama produce bait minnows (*Pimephales promelas* and *Notemigonus crysoleucas*), ornamental fish such as koi carp (*Cyprinus carpio*) and goldfish (*Carassius auratus*), and fingerlings of largemouth bass (*Micropterus salmoides*), sunfish (*Lepomis* spp.), and grass carp (*Ctenopharyngodon idellus*). These species usually are cultured in small, earthen ponds (0.1 to 3 acres). Both embankment and watershed ponds are used, and water sources normally are a combination of overland flow and water from streams and wells. Ponds usually are treated with fertilizer and feed is applied in many cases. Stocking rates normally are not high, and mechanical aeration is not necessary. Ponds usually are drained for harvest.

Explanation

The main environment issue related to the production of minnows, fingerlings, and ornamental fish is effluents. Nutrients accumulate in ponds through the use of fertilizers and feeds, and only about 25% of these nutrients are removed from ponds in fish harvest. The procedures used for production of these species are similar to those used for channel catfish culture. The main difference is that catfish ponds have standing stocks of 5,000 to 10,000 lb/acre while bait minnow, fingerling, and ornamental fish ponds have standing stocks of only 1,000 to 2,000 lb/acre. Therefore, inputs of nutrients through the use of fertilizers and feeds are much less than in catfish farming. Moreover, most bait minnow, fingerling, and ornamental fish farms in Alabama reuse a considerable portion of pond water through recycling in efforts to conserve water, lower pumping costs, and conserve nutrients. In comparison with catfish farms, the release of nutrients per unit of production area is much less. Nevertheless, BMPs should be applied at bait minnow, fingerling, and

ornamental fish farms to assure good nutrient management, and to reduce effluent volume and potential pollution loads.

Sediment accumulation in the deeper parts of ponds is a major problem when harvesting small fish. Small fish become trapped in soft sediment making it difficult to remove them from ponds. The sediment can clog their gills and contribute to high mortality during harvest. When sediment is removed from ponds, it should be managed according to NRCS technical standards and guidelines to prevent it from entering streams in runoff.

Operating bait minnow, fingerling, and ornamental fish farms

Practices

All farms should install applicable practices from Aquaculture Best Management Practice (BMP) Nos. 1-15. In addition, the following practices should be used:

- *Management plans should be prepared by and practices implemented with the assistance of a professional engineer (PE) licensed in the State of Alabama or other qualified credentialed professional (QCP). Periodic inspections of the operation should also be conducted by a PE or QCP.*
- *When ponds are drained, water should be stored in adjacent ponds or in a reservoir for reuse.*
- *Sediment removed from ponds should be managed in a responsible manner according to NRCS technical standards and guidelines.*
- *Dead fish should be disposed in a responsible manner according to NRCS technical standards and guidelines*

Bait minnows, sportfish and grass carp fingerlings, and ornamental fish aquaculture systems that qualify as concentrated aquatic animal production (CAAP) facilities must comply with EPA effluent limitation guidelines, applicable NRCS technical standards and guidelines, and if required, ADEM NPDES permitting requirements.

Implementation notes

Implementation of applicable practices from BMP Nos. 1-15 will reduce pond discharge, improve the capacity of ponds to assimilate wastes, and reduce the pollution potential of pond effluents. Moreover, using BMPs to reduce erosion on pond watersheds and within ponds will reduce the rate of sediment accumulation in deeper areas of ponds.

A moderate density of plankton is essential in early stages of grow-out when fish are too small to use commercial feed efficiently. Thus, producers can benefit from reusing water from previous crops because the water contains nutrients and plankton. This water is suitable for immediate use in fish culture. When ponds are refilled with clear water, fertilizers must be applied to encourage plankton blooms which may not develop for 1 or 2 weeks.

Ponds usually are small and water can be transferred with portable pumps between ponds or between ponds and a reservoir. A scheme that may be used in a complex of small ponds is illustrated in Figure 1. Water from the pond to be harvested is pumped to adjacent ponds. After the pond has been harvested, it is refilled by returning water via gravity flow through pipes extending through embankments. The scheme for water reuse illustrated in BMP No. 16 also is applicable for small ponds.

Small ponds have a large ratio of erodable embankment to pond bottom area when compared to larger aquaculture ponds such as those used for catfish. This can result in a large volume of internally-derived sediment which accumulates in the deepest areas of ponds where fish harvesting is finalized. Moreover, ponds are drained annually, and this facilitates the movement of soft sediment into the deepest area. Thus, instead of redistributing sediment over pond bottoms and embankments as recommended for catfish and shrimp ponds (BMP Nos. 4 and 16), it often is desirable to remove sediment. This sediment should be land applied to fields or pastures in thin layers and erosion prevention measures applied in accordance with NRCS technical standards and guidelines. Chlorides concentration and saline water management is considered in BMP No. 16.

References

- ADEM Administrative Code Chapter 335-6-6. (NPDES Rules)
- Boyd, C. E., J. F. Queiroz, G. N. Whitis, R. Hulcher, P. Oakes, J. Carlisle, D. Odom, Jr., M. M. Nelson, and W. G. Hemstreet. 2003. Best management practices for channel catfish farming in Alabama. Special Report 1, Alabama Catfish Producers, Montgomery, Alabama.
- Chapman, F. A. 2000. Ornamental fish culture, freshwater, pages 602-610. In: R. R. Stickney (editor), *Encyclopedia of Aquaculture*. John Wiley and Sons, New York, New York.
- Stone, N. 2000. Baitfish culture, pages 97-104. In: R. R. Stickney (editor), *Encyclopedia of Aquaculture*. John Wiley and Sons, New York, New York.

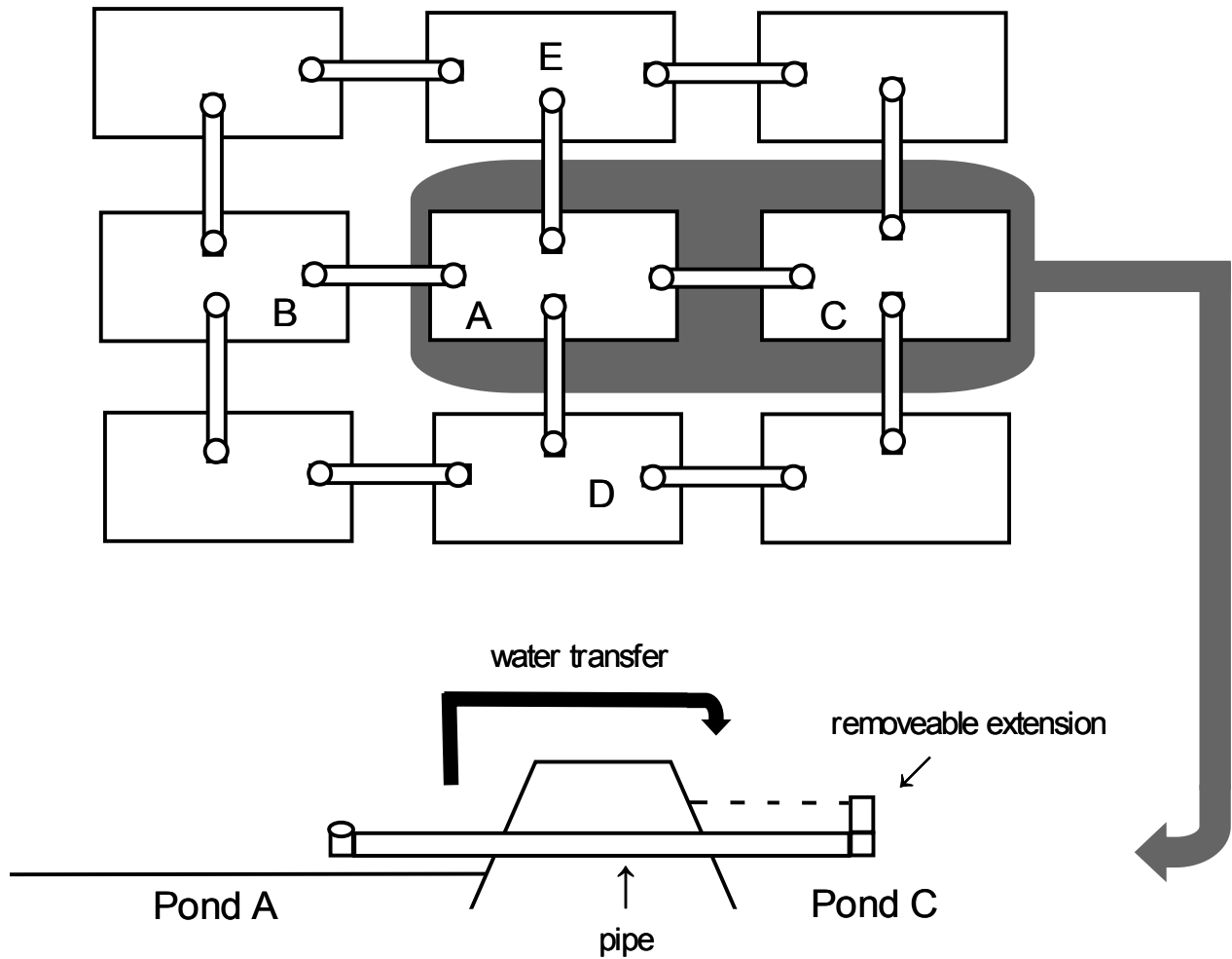

Figure. 1. Illustration of a method for conserving water for reuse in a complex of small aquaculture ponds. Extension pipes are inserted into the ends of pipes in ponds B, C, D, and E. Water is pumped from pond A into these ponds. After harvest of pond A, the extension pipes are removed and water flows back into pond A.

This project was funded or partially funded by the Alabama Department of Environmental Management through a Clean Water Act Section 319(h) nonpoint source grant provided by the U.S. Environmental Protection Agency.



Auburn University is an equal opportunity educational institution.

"The U.S. Department of Agriculture (USDA) prohibits discrimination in all its programs and activities on the basis of race, color, national origin, sex, religion, age, disability, political beliefs, sexual orientation, and marital or family status. (Not all prohibited bases apply to all programs.) Persons with disabilities who require alternative means for communication of program information (Braille, large print, audiotape, etc.) should contact USDA's TARGET Center at (202) 720-2600 (voice and TDD). To file a complaint of discrimination write USDA, Director, Office of Civil Rights, Room 326-W, Whitten Building, 14th and Independence Avenue, SW, Washington, DC 20250-9410 or call (202) 720-5964 (voice or TDD). USDA is an equal opportunity provider and employer."